



3D EM SYSTEMS MATCHING BUSINESS



UNIQUE LOOK
EXEPTIONAL
PERFORMANCE

PREMIUM

The TAGIT Premium System is manufactured using high quality precision machined acrylic material. It has a translucent & glittery look, which makes it aesthetically pleasing and resistant to abrasion and wear.

Its patented 3D detection produces high level detection in all three label orientations with an enhanced aisle width of up to 110cm – subject to the configuration and onsite electrical noise level.

This innovative new system has been designed to meet the exit protection needs of a wide range of applications including: high-end cosmetic stores, libraries, archives, book stores, pharmacies, wine shops, galleries etc. The TAGIT Premium System is supplied on a worldwide basis.

- » SUPERIOR 3D DETECTION ©
- » DETECTS LABELS ON METAL
- » DETECTS LABELS COVERED IN ALUMINUM FOIL
- » ALARM CAN TRIGGER CAMERA
- » DESIGN MEETS HIGH QUALITY REQUIREMENTS

PREMIUM | TAGIT 3D EM ANTENNA

Dimensions	height: 161 cm 63 inch width: 67 cm 26 inch base thickness: 9 cm 3.5 inch
Voltage	100 V — 240 Vac; 50/60Hz; grounded
Power Consumption	max. 130VA per antenna
TX Frequency	ca. 200 Hz
Weight Master Antenna	41 kg
Weight Slave Antenna	40.8 kg
Power supply	6 kg
Alarm	visual / audio signal optional (NO/NC Relay output) programmable sound and light alarm sequences



The power supply unit is used for single and dual aisle systems. Three antennas can be supplied by one PSU, if the power line is 230V.





**FLEXIBILITY
MATCHING
BUSINESS**

PREMIUM LIGHT

The TAGIT Premium Light System is manufactured using acrylic material. It has an attractive translucent appearance, and is highly resistant to wear. Its patented 3D detection produces high level detection in all three label orientations with an enhanced aisle width of up to 130cm – subject to the configuration and on-site electrical noise level.

This system is designed for general retailers and the protection of confidential/valuable documents within high-tech companies, government institutions, libraries and archives.

Our standard colours are white and black, and other colours are available on request.

- » SUPERIOR 3D DETECTION ©
- » DETECTS LABELS ON METAL
- » DETECTS LABELS COVERED IN ALUMINUM FOIL
- » FLEXIBLE HEIGHT

PREMIUM LIGHT | TAGIT 3D EM ANTENNA

Dimensions	height: 158 cm 62 inch width: 64 cm 25 inch base thickness: 9 cm 3.5 inch
Voltage	100 V — 240 Vac; 50/60Hz; grounded
Power Consumption	max. 130VA per antenna
TX Frequency	ca. 200 Hz
Weight Master Antenna	27 kg
Weight Slave Antenna	26.8 kg
Power supply	6 kg
Alarm	visual / audio signal optional (NO/NC Relay output) programmable sound and light alarm sequences



The power supply unit is used for single and dual aisle systems. Three antennas can be supplied by one PSU, if the power line is 230V.



SECURITY TAKES ON COLOR

FORTUNA

The TAGIT Fortuna System is manufactured using high quality materials, and employs our patented 3D detection technology to provide an installation distance of up to 130cm with a high level detection in all three label orientations. The installation distance achievable depends upon the configuration and the level of onsite electrical noise.

This system is designed for the protection of confidential/valuable documents within high-tech companies, government institutions, libraries, archives and retail applications. Our standard colour is white, with other colours available on request.

- » SUPERIOR 3D DETECTION ©
- » DETECTS LABELS ON METAL
- » DETECTS LABELS COVERED IN ALUMINUM FOIL
- » EXCELLENT SURFACE FOR ADVERTISEMENTS

FORTUNA | TAGIT 3D EM ANTENNA

Dimensions	modifiable standard height: 157 cm 62 inch width: 64 cm 25 inch thickness of antenna frame: 2,5 cm 1 inch base thickness: 9 cm 3,5 inch
Voltage	100 V — 240 Vac; 50/60Hz; grounded
Power Consumption	max. 130VA per antenna
TX Frequency	ca. 200 Hz
Weight Master Antenna	21,2 kg
Weight Slave Antenna	21 kg
Power supply	6 kg
Alarm	visual / audio signal optional (NO/NC Relay output) programmable sound and light alarm sequences



The power supply unit is used for single and dual aisle systems. Three antennas can be supplied by one PSU, if the power line is 230V.





EUREKA

The TAGIT Eureka System is manufactured using high quality materials, and employs our patented 3D detection technology to provide an installation distance of up to 110cm with a high level detection in all three label orientations. The installation distance achievable depends upon the specific configuration and the level of onsite electrical noise.

This system is designed for exit and cash desk protection in cosmetic stores, libraries, archives, book stores, pharmacies and groceries. The TAGIT Eureka System is supplied on a worldwide basis.

- » SUPERIOR 3D DETECTION ©
- » DETECTS LABELS ON METAL
- » DETECTS LABELS COVERED IN ALUMINUM FOIL
- » GUARDED APPEARANCE

EUREKA | TAGIT 3D EM ANTENNA

Dimensions	height: 159 cm 62.5 inch width: 70 cm 27.6 inch base thickness: 11 cm 4.3 inch
Voltage	100 V — 240 Vac; 50/60Hz; grounded
Power Consumption	max. 130VA per antenna
TX Frequency	ca. 200 Hz
Weight Master Antenna	29,5 kg
Weight Slave Antenna	29 kg
Power supply	6 kg
Alarm	visual / audio signal optional (NO/NC Relay output) programmable sound and light alarm sequences



The power supply unit is used for single and dual aisle systems. Three antennas can be supplied by one PSU, if the power line is 230V.

SYSTEM CONFIGURATIONS

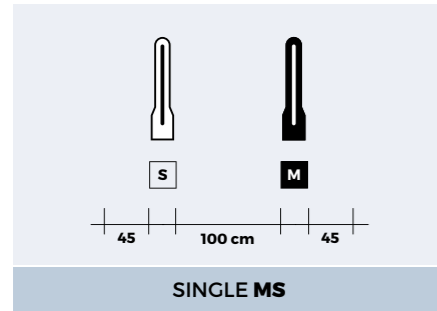

Used in normal noise conditions. One system with two antennas. The protected area is up to 100 cm between the antennas, plus 45cm outside the antennas.

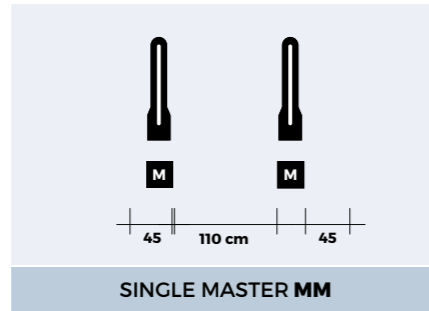

Recommended for medium noise level conditions. One system with two antennas working independently. The protected area is up to 110cm between the antennas, plus 45cm outside the antennas.

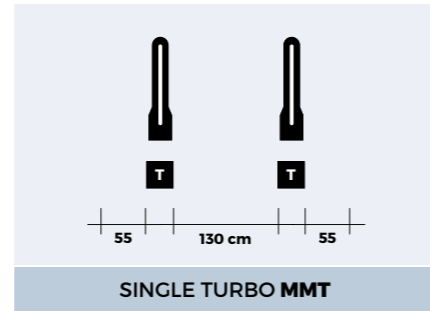

Ideal for high noise level conditions. One system with two antennas working independently, using double DSP in each master antenna. The protected area is up to 130cm between the antennas, plus 55cm outside the antennas.

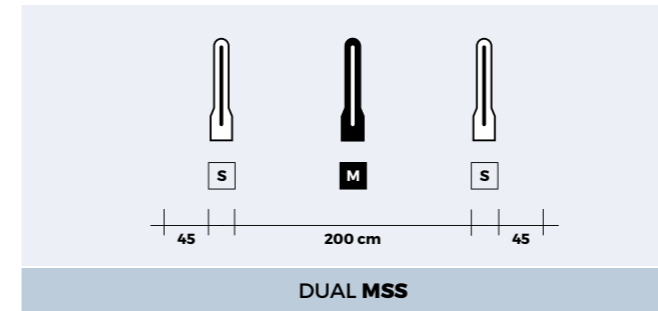

Used in normal noise level conditions. One system with three antennas. The protected area is up to 200cm between the antennas, plus 45cm outside the antennas.

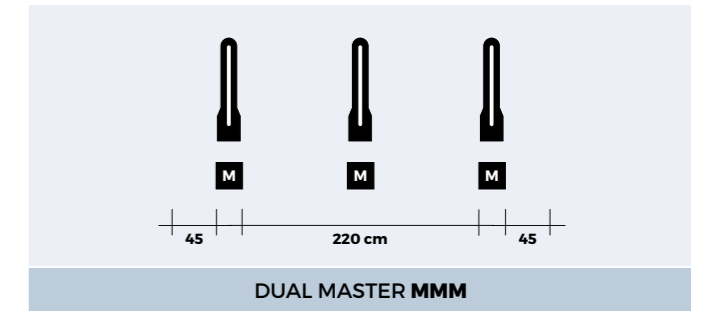

Recommended for medium noise level conditions. One system with three antennas uses two power supplies. Precise identification in which area the detection takes place. The protected area is up to 220cm between the antennas, plus 45cm outside the antennas..

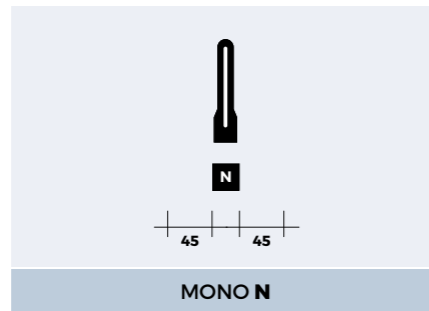

Recommended for medium noise level conditions. One system works independently. The protected area is up to 2x 45cm. Used as an extension for existing configurations.

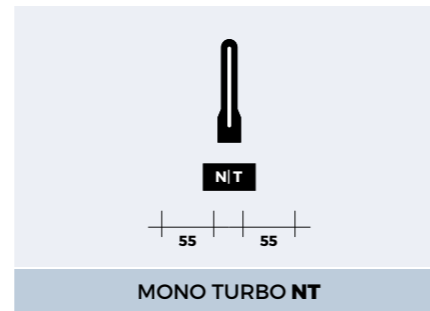

Ideal for high noise level conditions. One system with a double DSP working independently. The protected area is up to 2x 55cm. Used as an extension for existing configurations.

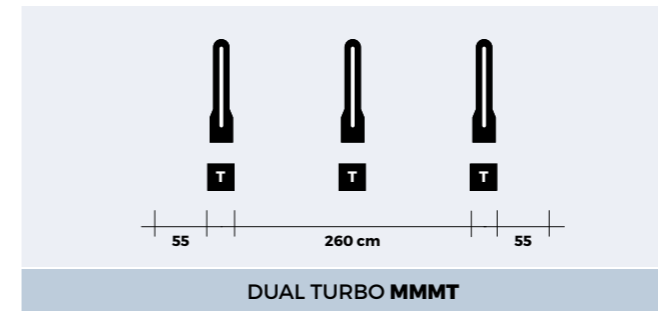

Ideal for high noise level conditions. One system with three antennas uses two power supplies and double DSP in each master antenna. Precise identification in which area the detection takes place. The protected area is up to 260cm between the antennas, plus 55cm outside the antennas..

SINGLE AISLE SYSTEM

	MS	MM	MMT	NN	NNT
Detection Range cm / inch	100 / 39	110 / 43	130 / 51	110 / 43	260 / 102
Power Supply	1	1	1	—	—
Power Supply for 110V countries	1	1	1	—	—
AC/DC adaptor	—	—	—	2	2
Slave Antenna	1	—	—	—	—
Master Antenna	1	2	—	2	—
Master Turbo	—	—	2	—	2

DUAL AISLE SYSTEM

	MSS	MMM	MMMT	NNN	NNNT
Detection Range cm / inch	200 / 79	220 / 87	260 / 102	220 / 87	260 / 102
Power Supply	1	1	2	—	—
Power Supply for 110V countries	2	2	2	—	—
AC/DC adaptor	—	—	—	3	3
Slave Antenna	2	—	—	—	—
Master Antenna	1	3	—	3	—
Master Turbo	—	—	3	—	3